

Thermodyne's 300NDNL counter-top holding unit provides food quality and kitchen efficiency like no other piece of equipment on the market today. Using patented Fluid Shelf® technology each shelf in the cabinet maintains an exact temperature, allowing for extended holding times, without sacrificing appearance or taste. This compact unit requires no door and includes our exclusive removable floating lid system. It is available as pass through or with a solid panel back.



Unit shown with optional pans and lids

SPECIFICATIONS			
EXTERIOR DIMENSIONS	444.50W	x	584.20D x 657.35H
INTERIOR DIMENSIONS	342.90W	x	558.80D x 514.35H
MAX OPERATING TEMP	110°C		
NET WEIGHT	55.8kg.		
SHIPPING WEIGHT	83.9kg.		

ELECTRICAL SPECIFICATIONS			
VOLTS	220	230	240
AMPS	11	12	13
TOTAL WATTS	2520	2755	3000
HERTZ	50	50	50
PHASE	1	1	1
PLUG	BS1363/A / EU1-16P		

SHELVES	
STANDARD	5

CAPACITY	
GASTRONORM PAN	
GN 1/1 65 mm	5

OPTIONS / ACCESSORIES	
High Temp Pans	Vented Stainless Drawer Lids
Pass-thru	Stainless Drawer Lids
Wire Baskets	Stainless Steel Riser

Specifications subject to change without notice.

FRONT VIEW

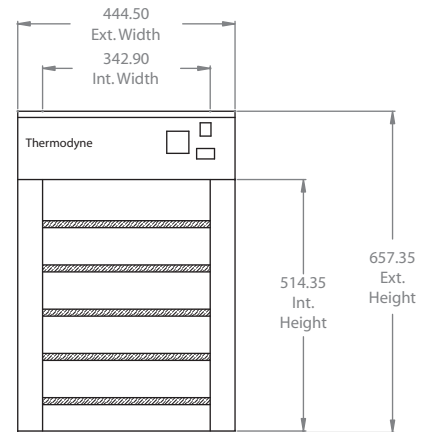

SIDE VIEW

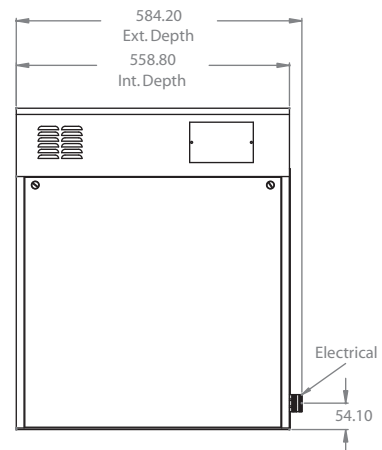

PLAN VIEW

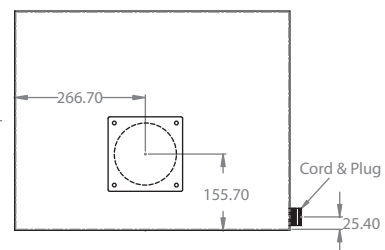

Patented REV. 11/15

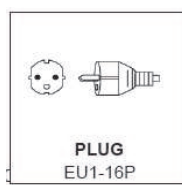
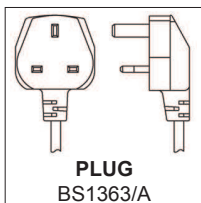

Compass International Co. Inc., International Sales / 2413 Pond Branch Road, Leesville, SC 29070 USA
Tel: ++1-803-359-1226 / Fax: ++1-803-359-1245 / Email: thermodyne@compassintlco.com

www.tdyne.com

UK Sales: Kitchen Restaurant Projects. +44 07398 885224
Rob.Gibson@kandrprojects.co.uk / www.kandrprojects.co.uk

FluidShelf
Precision Heat Transfer System