

Designed as a dimensional alternative to the 1200G, Thermodyne's 1200DW offers additional space for side by side pan placement along with double doors for tight areas that require a narrow door swing. The 1200DW offers all of the benefits of Fluid Shelf® technology in a compact single stack unit and can be ordered with an optional base extension.



SPECIFICATIONS			
EXTERIOR DIMENSIONS	774.70W	x	657.35D x 1085.85H
INTERIOR DIMENSIONS	673.10W	x	571.50D x 742.95H
MAX OPERATING TEMP	110°C		
NET WEIGHT	112.9kg.		
SHIPPING WEIGHT	163.3kg.		

ELECTRICAL SPECIFICATIONS			
VOLTS	220	230	240
AMPS	11	12	13
TOTAL WATTS	2520	2755	3000
HERTZ	50	50	50
PHASE	1	1	1
PLUG	BS1363/A / EU1-16P		

SHELVES	
STANDARD	5

CAPACITIES	STANDARD	MAXIMUM*
GASTRONORM PAN		
GN 1/1 65mm	10	14
GN 1/1 100mm	10	10

*Maximum capacities are based on additional shelving. Capacities vary depending on shelf quantities, spacing, and pan depth.

OPTIONS / ACCESSORIES	
Protective Bumper Base	Additional Heat Transfer Plates
Extension Base	Solid Stainless Steel Doors
Solid Back Panel	Stainless Steel Drip Pan

Specifications subject to change without notice.

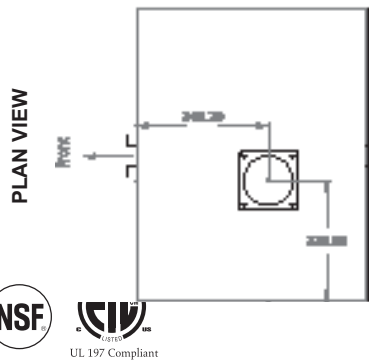
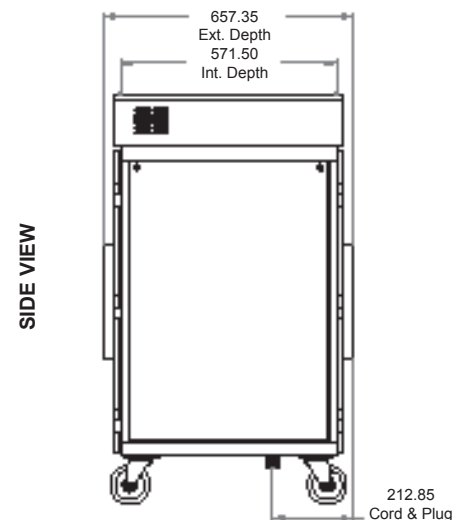
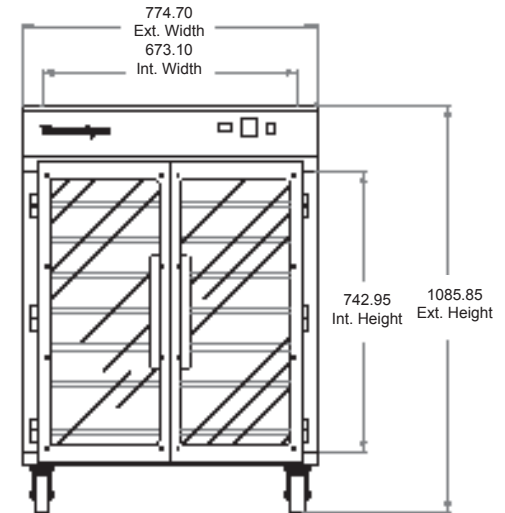

Patented REV. 11/15

